

## High Efficiency Solar Cell

Maxeon® Technology

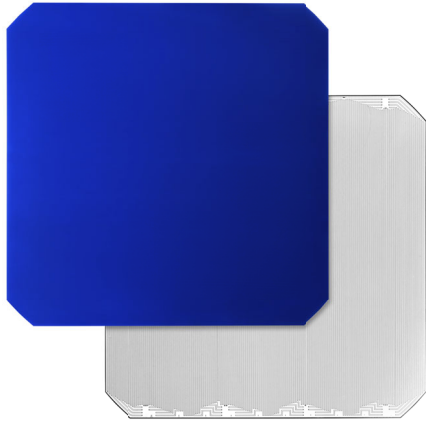

### Highest Power Density Available

The Maxeon Gen 6 cell is 6% larger than the prior generations, delivering the most powerful cell and highest efficiency panel on the commercial market.

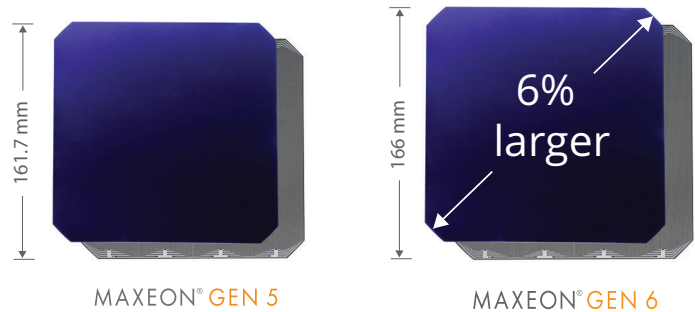

### Fundamentally Different. And Better.

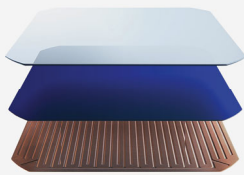

#### Maxeon® Technology

- Ultra-pure, n-type, monocrystalline silicon for maximum power
- Tin barrier prevents corrosion
- Uniquely durable back-contact design with no ribbons
- Clean and elegant aesthetics by designing out front contacts



#### Trusted Durability

- Solid metal foundation helps cell bend where others break under pressure.
- Conductive and malleable foundation keeps cell electrically intact even if eventually cracked.



### Born to Break Records

Maxeon cells powered the first solar circumnavigation of the planet by air and by sea. They are the chosen technology by pioneers who demand the best in harsh environments.



### Proven Technology Platform

Maxeon has deployed more than one billion cells across more than 9 GW of installed solar - with a very low warranty return rate of 0.005%. Maxeon's industry-leading R&D team has invested deeply in generations of incremental design enhancements over three decades.

# Maxeon® Gen 6 High Efficiency Solar Cell

## Electrical Characteristics of typical Maxeon Gen 6 Cell

Cell Bins	Pmpp (Wp)	Eff (%)	Vmpp (V)	Imp (A)	Voc (V)	Isc (A)
Mn1	6.71	24.5	0.620	10.82	0.731	11.53
Tsc	6.616	24.3	0.615	10.78	0.729	11.5
Kn2	6.03	22.0	0.584	10.33	0.724	11.24
Kn3	5.70	20.8	0.562	10.16	0.728	11.13

Temperature Coefficients in SunPower Panels: Voltage: -0.239%/°C, Current: 0.057%/°C, Power: -0.29%/°C

## Spectral Response

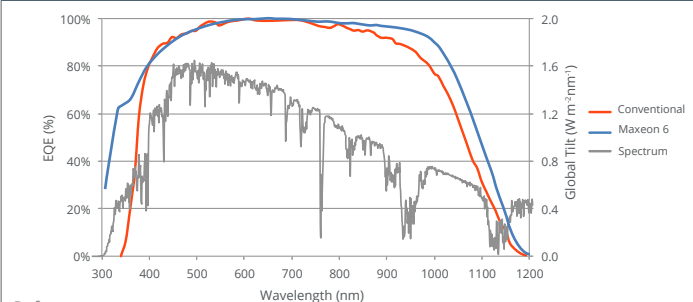

References  
 Conventional: Green, M.a., Emery, K., Hishikawa, Y., & Warta, W. (2010). Solar cell efficiency tables (version 36). Progress in Photovoltaics: Research and Applications, 18(5), 46-352. doi:10.1002/pip/1021  
 SunPower: NREL data, commissioned by SPWR: "Gen C CS AR bin". 2013.  
 Spectrum: Standard, ASTM. "G173-03." URL: http://www.astm.org

## Cell Physical Characteristics

Wafer: Monocrystalline silicon  
 Design: All back contact  
 Front: Uniform, black antireflection coating  
 Back: Tin-coated, copper metal grid  
 Cell Area: Approximately 274.15cm<sup>2</sup>  
 Cell Weight (Min-Max): Approximately 12grams  
 Cell Thickness (Min-Max): 152µm +/- 8µm

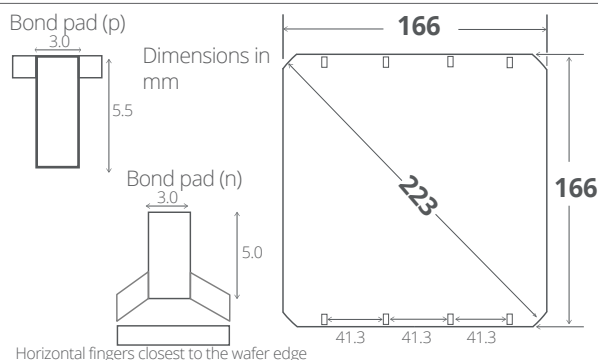

Bond pad area dimensions are 5.0mm x 3.0mm (npad)  
 Bond pad area dimensions are 5.5mm x 3.0mm (ppad)  
 Metal finger pitch is 520µm (whether positive or negative finger)

## Positive Electrical Grounding

If cell voltage is below frame ground the cell power output will be reduced. Therefore, modules and systems produced using these cells should be configured as "positive ground system". If this creates a problem, please consult with Maxeon.

## Interconnect Tab and Process Recommendations

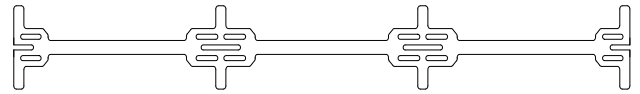

Maxeon recommends customers use Maxeon's patented tin-plated copper strain-relieved interconnect tabs, which can be purchased from Maxeon. These interconnects are easily solderable and compatible with lead free processing solder paste. Tab weigh approximately 0.5 grams.

Our patented interconnect tabs are packaged in reeled format or 15,000 each.

<https://sunpower.maxeon.com/int/virtual-patent-marking>

## Production Quality

ISO 9001:2015 certified  
 Soft handling procedures to reduce breakage and crack formation  
 100% cell performance testing and visual inspection.

## Sustainability



## MSDS

Maxeon cells are subject to certification and regulations under UL, TUV, JET and other regulatory agencies. As an end-product under these agencies, Maxeon end-products are not required to travel with an MSDS.

## Packaging

Cells are packed in boxes of 1200 each; grouped in 8 shrink wrapped stacks of 150 with interleaving. 1 pallet containing 36,000 cells suitable for air transport.

## Purchase Terms

Customers shall not reverse engineer, disassemble or analyze the Solar Cells or any prototype, process, product, or other item that embodies Confidential Information of Maxeon. Customers shall not cause or allow any inspection, analysis, or characterization of any properties (whether mechanical, structural, chemical, electrical, or otherwise) of the Solar Cells, whether by itself or by a third party. Customer agrees that it will not transfer (whether by sale, loan, gift, or other conveyance) the Solar Cells from its possession. Maxeon solar cells are provided "AS IS" without warranty. Full terms and conditions are in the Cell Purchase Agreement